

RSR·SRS Comparison dimensions table

#5,5W

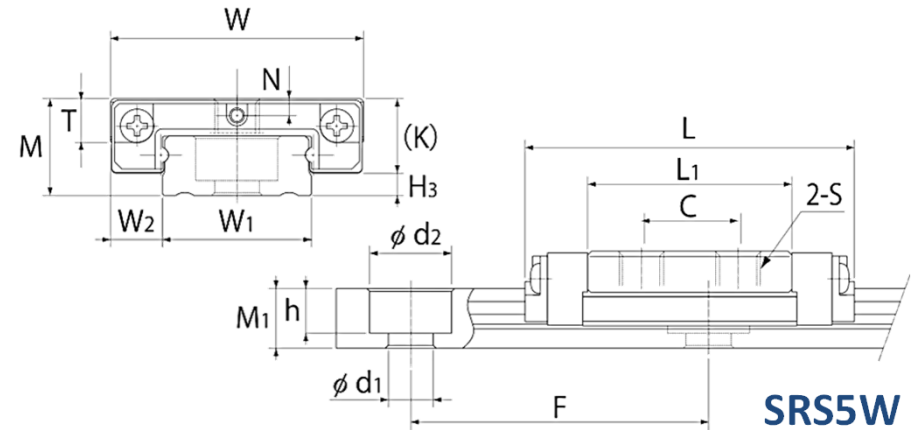
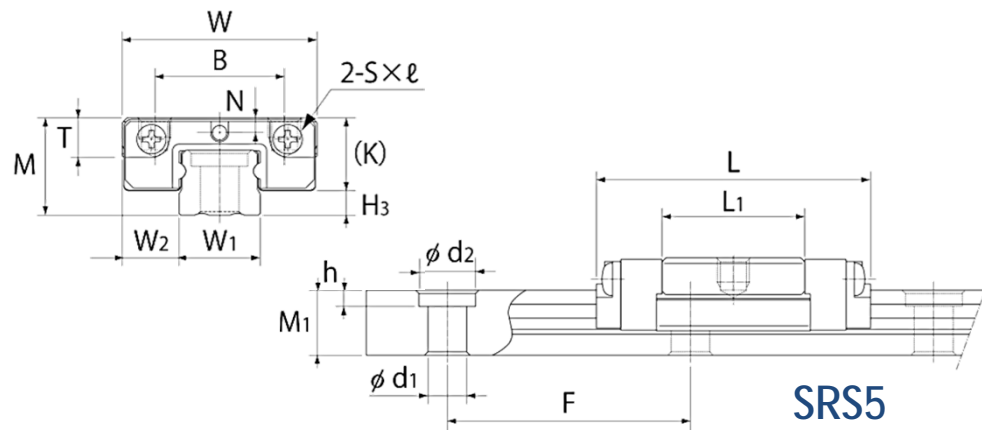

···RSR ···SRS

Block type	Model No.	Outer dimensions			LM block dimensions							LM rail dimensions						Basic load rating		
		Height M	Width W	Length L	B	C	S x l	L1	T	K	N	H3	Width W1	W2	W3	Height M1	Pitch F	d1*d2*h	C kN	C0 kN
5M	RSR 5M	6	12	16.9	8	-	M2*1.5	8.8	-	4.5	0.8	1.5	5	3.5	-	4	15	2.4*3.5*1	0.32	0.59
	SRS 5M	6	12	16.9	8	-	M2*1.5	8.8	1.7	4.5	0.93	1.5	5	3.5	-	4	15	2.4*3.5*1	0.439	0.468
	SRS 5GM	6	12	16.9	8	-	M2*1.5	8.8	1.7	4.5	0.93	1.5	5	3.5	-	4	15	2.4*3.5*1	0.366	0.527
5N	RSR 5N	6	12	20.1	-	7	M2.6*1.8	12	-	4.5	0.8	1.5	5	3.5	-	4	15	2.4*3.5*1	0.55	0.96
	SRS 5N	6	12	20.1	8	-	M2*1.5	12	1.7	4.5	0.93	1.5	5	3.5	-	4	15	2.4*3.5*1	0.515	0.586
	SRS 5GN	6	12	20.1	8	-	M2*1.5	12	1.7	4.5	0.93	1.5	5	3.5	-	4	15	2.4*3.5*1	0.448	0.703
	RSR 5TN	6	12	20.1	8	-	M2*1.5	12	-	4.5	0.8	1.5	5	3.5	-	4	15	2.4*3.5*1	0.55	0.96
5WM	RSR 5WM	6.5	17	22.1	-	6.5	M3*2.3	13.7	-	5	1.1	1.5	10	3.5	-	4	20	3*5.5*3	0.51	0.96
	SRS 5WM	6.5	17	22.1	-	6.5	M3通シ	13.7	2.7	5	1.1	1.5	10	3.5	-	4	20	3*5.5*3	0.584	0.703
	SRS 5WGM	6.5	17	22.1	-	6.5	M3通シ	13.7	2.7	5	1.1	1.5	10	3.5	-	4	20	3*5.5*3	0.498	0.82
	RSR 5WTM	6.5	17	22.1	13	-	M2.5*1.5	13.7	-	5	1.1	1.5	10	3.5	-	4	20	3*5.5*3	0.51	0.96
5WN	RSR 5WN	6.5	17	28.1	-	11	M3*2.3	19.7	-	5	1.1	1.5	10	3.5	-	4	20	3*5.5*3	0.75	1.4
	SRS 5WN	6.5	17	28.1	-	11	M3通シ	19.7	2.7	5	1.1	1.5	10	3.5	-	4	20	3*5.5*3	0.746	0.996
	SRS 5WGN	6.5	17	28.1	-	11	M3通シ	19.7	2.7	5	1.1	1.5	10	3.5	-	4	20	3*5.5*3	0.64	1.17
	RSR 5WTN	6.5	17	28.1	13	-	M2.5*1.5	19.7	-	5	1.1	1.5	10	3.5	-	4	20	3*5.5*3	0.75	1.4

RSR·SRS Comparison dimensions table

#7,7W

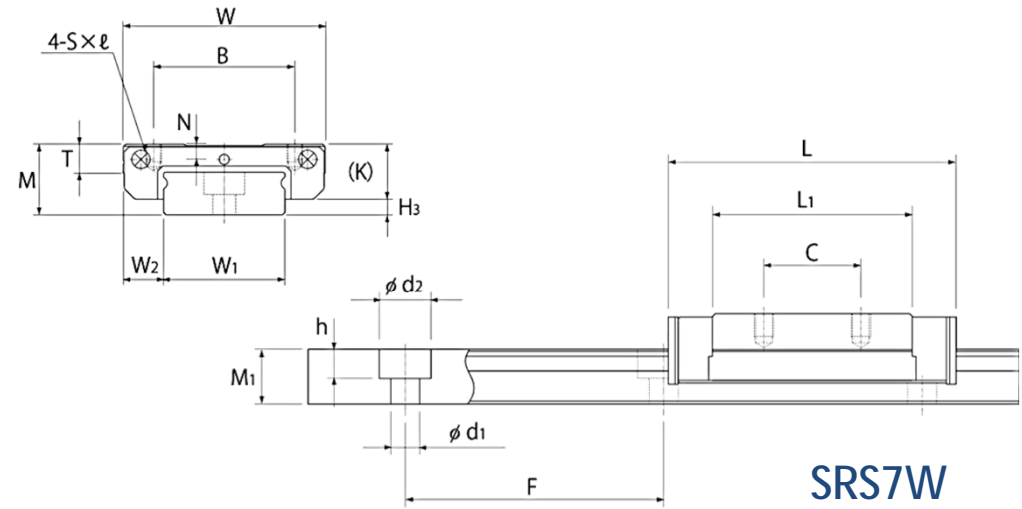
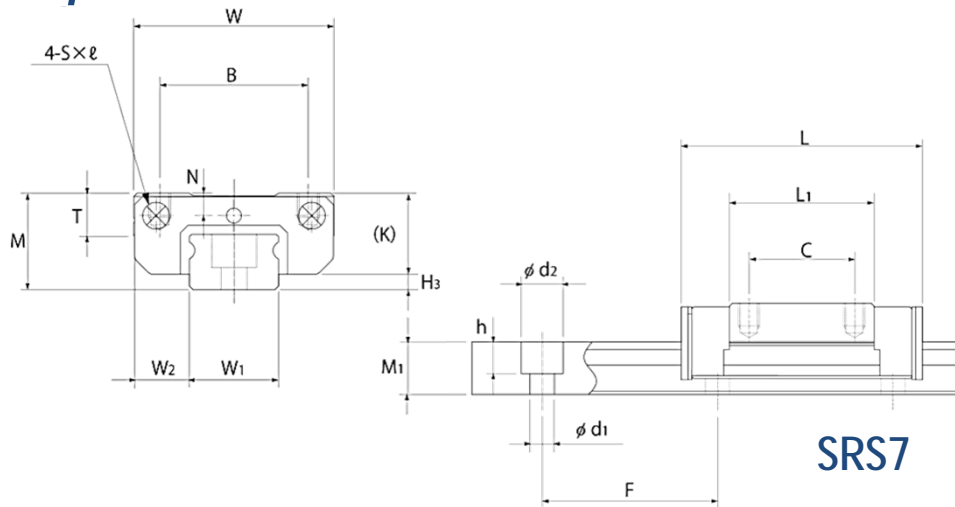

... RSR
 ... SRS

Block type	Model No.	Outer dimensions			LM block dimensions							LM rail dimensions						Basic load rating		
		Height M	Width W	Length L	B	C	S x l	L1	T	K	N	H3	Width W1	W2	W3	Height M1	Pitch F	d1*d2*h	C kN	C0 kN
7S	SRS 7S	8	17	19	12	-	M2*2.3	9	3.3	6.7	1.6	1.3	7	5	-	4.7	15	2.4*4.2*2.3	1.09	0.964
	SRS 7GS	8	17	19	12	-	M2*2.3	9	3.3	6.7	1.6	1.3	7	5	-	4.7	15	2.4*4.2*2.3	0.946	1.16
7M	RSR 7M	8	17	23.4	12	8	M2*2.5	13.4	-	6.5	1.7	1.5	7	5	-	4.7	15	2.4*4.2*2.3	0.88	1.37
	SRS 7M	8	17	23.4	12	8	M2*2.3	13.4	3.3	6.7	1.6	1.3	7	5	-	4.7	15	2.4*4.2*2.3	1.51	1.29
	RSR 7ZM	8	17	23.4	12	8	M2*2.5	13.2	3.4	6.5	1.6	1.5	7	5	-	4.7	15	2.4*4.2*2.3	0.88	1.37
7N	SRS 7GM	8	17	23.4	12	8	M2*2.3	13.4	3.3	6.7	1.6	1.3	7	5	-	4.7	15	2.4*4.2*2.3	1.16	1.54
	RSR 7N	8	17	33	12	13	M2*2.5	23	-	6.5	1.7	1.5	7	5	-	4.7	15	2.4*4.2*2.3	1.59	2.5
	SRS 7N	8	17	31	12	13	M2*2.3	21	3.3	6.7	1.6	1.3	7	5	-	4.7	15	2.4*4.2*2.3	2.01	2.31
7WS	SRS 7GN	8	17	31	12	13	M2*2.3	21	3.3	6.7	1.6	1.3	7	5	-	4.7	15	2.4*4.2*2.3	1.63	2.51
	RSR 7WS	9	25	22.5	19	-	M3*2.8	11.9	3.8	7.2	1.8	1.8	14	5.5	-	5.2	30	3.5*6*3.2	1.38	1.35
	SRS 7WGS	9	25	22.5	19	-	M3*2.8	11.9	3.8	7.2	1.8	1.8	14	5.5	-	5.2	30	3.5*6*3.2	1.06	1.35
7WM	RSR 7WM	9	25	31	-	12	M4*3.5	20.4	-	7	1.6	2	14	5.5	-	5.2	30	3.5*6*3.2	1.37	2.16
	SRS 7WM	9	25	31	19	10	M3*2.8	20.4	3.8	7.2	1.8	1.8	14	5.5	-	5.2	30	3.5*6*3.2	2.01	1.94
	RSR 7WTM	9	25	31	19	8	M3*3	20.4	-	7	1.6	2	14	5.5	-	5.2	30	3.5*6*3.2	1.37	2.16
	SRS 7WZM	9	25	31.5	19	10	M3*2.5	19.7	3.4	7	1.8	2	14	5.5	-	5.2	30	3.5*6*3.2	1.37	2.16
	RSR 7WGM	9	25	31	19	10	M3*2.8	20.4	3.8	7.2	1.8	1.8	14	5.5	-	5.2	30	3.5*6*3.2	1.63	2.51
7WN	SRS 7WN	9	25	40.9	-	18	M4*3.5	30.3	-	7	1.6	2	14	5.5	-	5.2	30	3.5*6*3.2	2.04	3.21
	RSR 7WTN	9	25	40.9	19	17	M3*3	30.3	-	7	1.6	2	14	5.5	-	5.2	30	3.5*6*3.2	2.04	3.21
	SRS 7WN	9	25	42	19	17	M3*2.8	31.4	3.8	7.2	1.8	1.8	14	5.5	-	5.2	30	3.5*6*3.2	2.56	3.28
	RSR 7WGN	9	25	42	19	17	M3*2.8	31.4	3.8	7.2	1.8	1.8	14	5.5	-	5.2	30	3.5*6*3.2	2.12	3.66

RSR·SRS Comparison dimensions table

#9X,9W

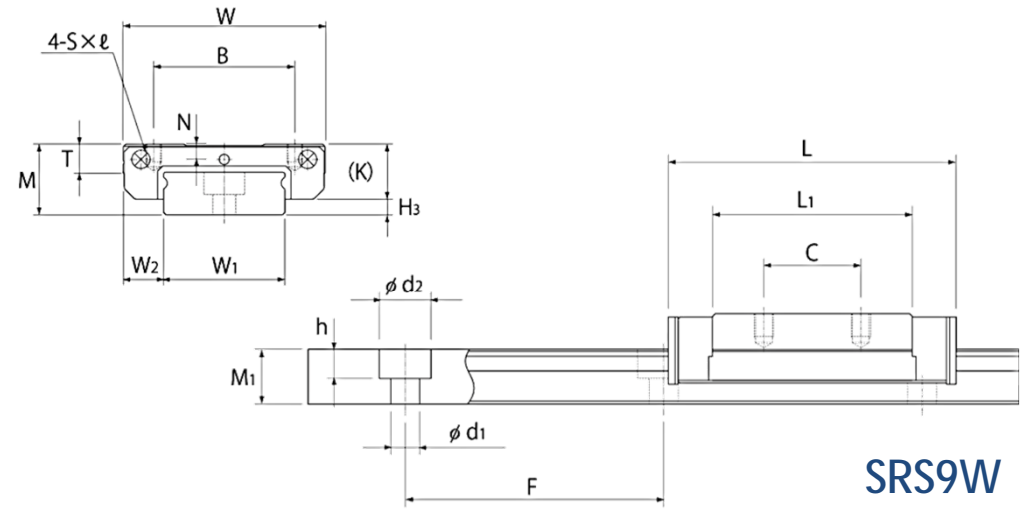
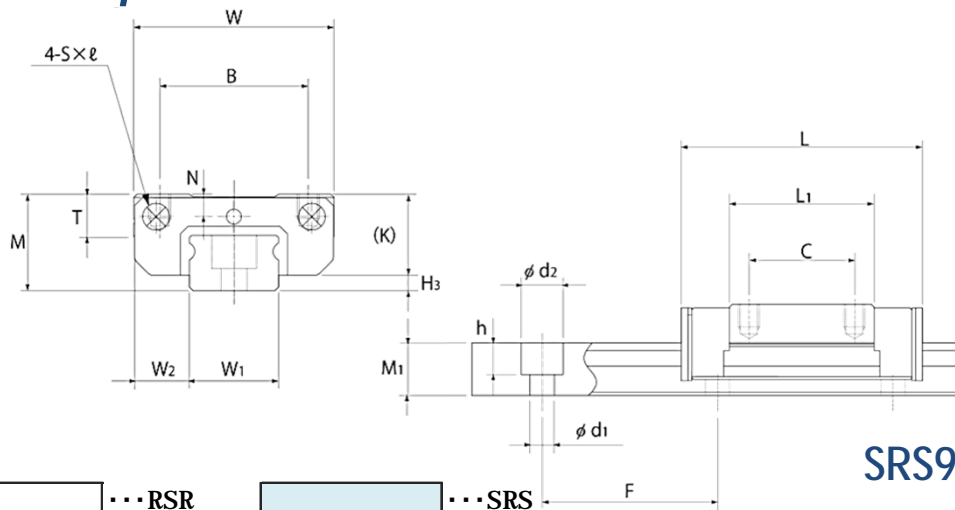

Block type	Model No.	Outer dimensions			LM block dimensions							LM rail dimensions					Basic load rating			
		Height M	Width W	Length L	B	C	S x l	L1	T	K	N	H3	Width W1	W2	W3	Height M1	Pitch F	d1*d2*h	C kN	C0 kN
9S	SRS 9XS	10	20	21.5	15	-	M3*2.8	10.5	4.5	8.5	2.4	1.5	9	5.5	-	5.5	20	3.5*6*3.3	1.78	1.53
	SRS 9XGS	10	20	21.5	15	-	M3*2.8	10.5	4.5	8.5	2.4	1.5	9	5.5	-	5.5	20	3.5*6*3.3	1.37	1.53
9M	RSR 9KM	10	20	30.8	15	10	M3*3	19.8	-	7.8	2.4	2.2	9	5.5	-	5.5	20	3.5*6*3.3	1.47	2.25
	SRS 9XM	10	20	30.8	15	10	M3*2.8	19.8	4.5	8.5	2.4	1.5	9	5.5	-	5.5	20	3.5*6*3.3	2.69	2.75
	RSR 9ZM	10	20	30.8	15	10	M3*2.7	19.4	4.6	7.8	2.4	2.2	9	5.5	-	5.5	20	3.5*6*3.3	1.47	2.25
	SRS 9XGM	10	20	30.8	15	10	M3*2.8	19.8	4.5	8.5	2.4	1.5	9	5.5	-	5.5	20	3.5*6*3.3	2.22	3.06
	RSR 9M1K	10	20	30.8	15	10	M3*3	19.8	-	7.8	-	2.2	9	5.5	-	5.5	20	3.5*6*3.3	1.47	2.25
9N	RSR 9N	10	20	40.8	15	16	M3*3	29.8	-	7.8	2.4	2.2	9	5.5	-	5.5	20	3.5*6*3.3	2.6	3.96
	SRS 9XN	10	20	40.8	15	16	M3*2.8	29.8	4.5	8.5	2.4	1.5	9	5.5	-	5.5	20	3.5*6*3.3	3.48	3.98
	SRS 9XGN	10	20	40.8	15	16	M3*2.8	29.8	4.5	8.5	2.4	1.5	9	5.5	-	5.5	20	3.5*6*3.3	2.94	4.59
9WS	RSR 9M1N	10	20	41	15	16	M3*3	29.8	-	7.8	-	2.2	9	5.5	-	5.5	20	3.5*6*3.3	2.6	3.96
	SRS 9WS	12	30	26.5	21	-	M3*2.8	14.5	4.9	9.1	2.3	2.9	18	6	-	7.5	30	3.5*6*4.5	2.03	1.84
9WM	SRS 9WGS	12	30	26.5	21	-	M3*2.8	14.5	4.9	9.1	2.3	2.9	18	6	-	7.5	30	3.5*6*4.5	1.73	2.14
	RSR 9WV	12	30	39	21	12	M2.6*3	27	-	7.8	2	4.2	18	6	-	7.5	30	3.5*6*4.5	2.45	3.92
9WN	RSR 9WVM	12	30	39	21	12	M2.6*3	27	-	7.8	2	4.2	18	6	-	7.5	30	3.5*6*4.5	2.45	3.92
	SRS 9WM	12	30	39	21	12	M3*2.8	27	4.9	9.1	2.3	2.9	18	6	-	7.5	30	3.5*6*4.5	3.29	3.34
	RSR 9WZM	12	30	39	21	12	M3*2.8	27	3.9	9.1	2.3	2.9	18	6	-	7.5	30	3.5*6*4.5	2.45	3.92
	SRS 9WGM	12	30	39	21	12	M3*2.8	27	4.9	9.1	2.3	2.9	18	6	-	7.5	30	3.5*6*4.5	2.67	3.35
	RSR 9M1WV	12	30	39	21	12	M2.6*3	27	-	7.8	2	4.2	18	6	-	7.5	30	3.5*6*4.5	2.45	3.92
9WN	SRS 9WN	12	30	50.7	23	24	M3*3	38.7	-	7.8	2	4.2	18	6	-	7.5	30	3.5*6*4.5	3.52	5.37
	RSR 9WN	12	30	50.7	23	24	M3*2.8	38.7	4.9	9.1	2.3	2.9	18	6	-	7.5	30	3.5*6*4.5	4.2	4.37
	SRS 9WGN	12	30	50.7	23	24	M3*2.8	38.7	4.9	9.1	2.3	2.9	18	6	-	7.5	30	3.5*6*4.5	3.48	5.81
	RSR 9M1WN	12	30	50.7	23	24	M3*3	38.7	-	7.8	2	4.2	18	6	-	7.5	30	3.5*6*4.5	3.52	5.37

RSR·SRS Comparison dimensions table

#12,12W

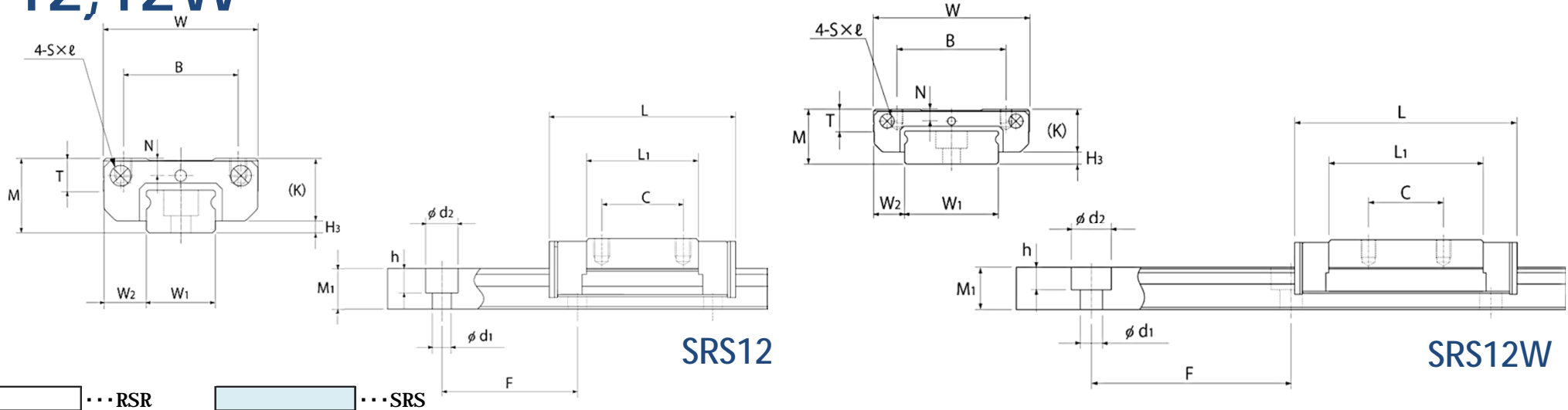

Block type	Model No.	Outer dimensions			LM block dimensions								LM rail dimensions					Basic load rating		
		Height M	Width W	Length L	B	C	S x l	L1	T	K	N	H3	Width W1	W2	W3	Height M1	Pitch F	d1*d2*h	C kN	C0 kN
12S	SRS 12S	13	27	25	20	-	M3*3.2	11.2	5.7	11	3	2	12	7.5	-	7.5	25	3.5*6*4.5	2.7	2.1
	SRS 12GS	13	27	25	20	-	M3*3.2	11.2	5.7	11	3	2	12	7.5	-	7.5	25	3.5*6*4.5	2.07	2.1
12M	RSR 12VM	13	27	35	20	15	M3*3.5	20.6	-	10	3	3	12	7.5	-	7.5	25	3.5*6*4.5	2.65	4.02
	SRS 12M	13	27	34.4	20	15	M3*3.2	20.6	5.7	11	3	2	12	7.5	-	7.5	25	3.5*6*4.5	4	3.53
	RSR 12ZM	13	27	35	20	15	M3*3.2	20.4	4.5	10.6	3.1	2.4	12	7.5	-	7.5	25	3.5*6*4.5	2.65	4.02
	SRS 12GM	13	27	34.4	20	15	M3*3.2	20.6	5.7	11	3	2	12	7.5	-	7.5	25	3.5*6*4.5	3.36	3.55
	RSR 12M1V	13	27	35	20	15	M3*3.5	20.6	-	10	3	3	12	7.5	-	7.5	25	3.5*6*4.5	2.65	4.02
12N	RSR 12N	13	27	47.7	20	20	M3*3.5	33.3	-	10	3	3	12	7.5	-	7.5	25	3.5*6*4.5	4.3	6.65
	SRS 12N	13	27	47.1	20	20	M3*3.2	33.3	5.7	11	3	2	12	7.5	-	7.5	25	3.5*6*4.5	5.82	5.3
	SRS 12GN	13	27	47.1	20	20	M3*3.2	33.3	5.7	11	3	2	12	7.5	-	7.5	25	3.5*6*4.5	4.72	6.83
	RSR 12M1N	13	27	47.7	20	20	M3*3.5	33.3	-	10	3	3	12	7.5	-	7.5	25	3.5*6*4.5	4.3	6.65
12WS	SRS 12WS	14	40	30.5	28	-	M3*3.5	16.9	5.7	11	3	3	24	8	-	8.5	40	4.5*8*4.5	3.58	3.15
	SRS 12WGS	14	40	30.5	28	-	M3*3.5	16.9	5.7	11	3	3	24	8	-	8.5	40	4.5*8*4.5	3.05	3.68
12WM	RSR 12WV	14	40	44.5	28	15	M3*3.5	30.9	4.5	10	3	4	24	8	-	8.5	40	4.5*8*4.5	4.02	6.08
	RSR 12WVM	14	40	44.5	28	15	M3*3.5	30.9	4.5	10	3	4	24	8	-	8.5	40	4.5*8*4.5	4.02	6.08
	SRS 12WM	14	40	44.5	28	15	M3*3.5	30.9	5.7	11	3	3	24	8	-	8.5	40	4.5*8*4.5	5.48	5.3
	RSR 12WZM	14	40	44.5	28	15	M3*3.6	29.3	4.5	10.6	3	3.4	24	8	-	8.5	40	4.5*8*4.5	4.02	6.08
	SRS 12WGM	14	40	44.5	28	15	M3*3.5	30.9	5.7	11	3	3	24	8	-	8.5	40	4.5*8*4.5	4.46	5.32
	RSR 12M1WV	14	40	44.5	28	15	M3*3.5	30.9	4.5	10	3	4	24	8	-	8.5	40	4.5*8*4.5	4.02	6.08
12WN	RSR 12WN	14	40	59.5	28	28	M3*3.5	45.9	4.5	10	3	4	24	8	-	8.5	40	4.5*8*4.5	5.96	9.21
	SRS 12WN	14	40	59.5	28	28	M3*3.5	45.9	5.7	11	3	3	24	8	-	8.5	40	4.5*8*4.5	7.13	7.07
	SRS 12WGN	14	40	59.5	28	28	M3*3.5	45.9	5.7	11	3	3	24	8	-	8.5	40	4.5*8*4.5	5.93	9.46
	RSR 12M1WN	14	40	59.5	28	28	M3*3.5	45.9	4.5	10	3	4	24	8	-	8.5	40	4.5*8*4.5	5.96	9.21

RSR·SRS Comparison dimensions table

#15,15W

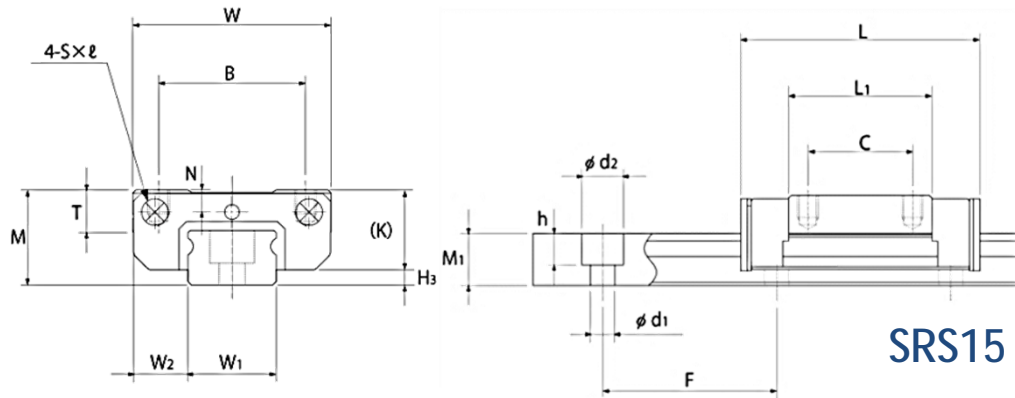

SRS15

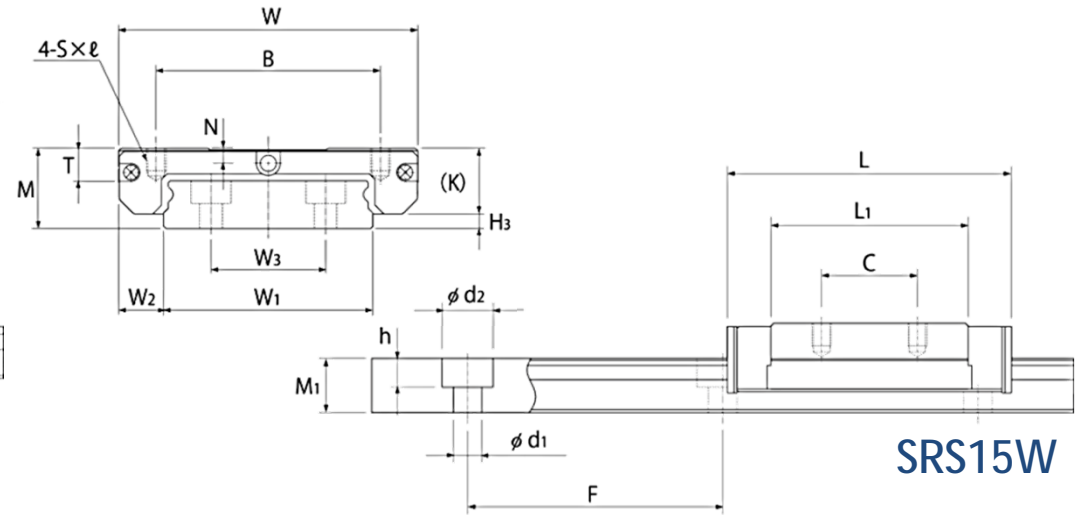

SRS15W

...RSR

...SRS

Block type	Model No.	Outer dimensions			LM block dimensions								LM rail dimensions						Basic load rating	
		Height M	Width W	Length L	B	C	S x l	L1	T	K	N	H3	Width W1	W2	W3	Height M1	Pitch F	d1 * d2 * h	C kN	C0 kN
15S	SRS 15S	16	32	32	25	-	M3*3.5	14.7	6.5	13.3	3	2.7	15	8.5	-	9.5	40	3.5*6*4.5	4.5	3.39
	SRS 15GS	16	32	32	25	-	M3*3.5	14.7	6.5	13.3	3	2.7	15	8.5	-	9.5	40	3.5*6*4.5	4.01	4.24
15M	RSR 15VM	16	32	42.9	25	20	M3*4	25.7	-	12	3.5	4	15	8.5	-	9.5	40	3.5*6*4.5	4.41	6.57
	SRS 15M	16	32	43	25	20	M3*3.5	25.7	6.5	13.3	3	2.7	15	8.5	-	9.5	40	3.5*6*4.5	6.66	5.7
	RSR 15ZM	16	32	43	25	20	M3*3.5	26.5	5.5	12.6	2.9	3.4	15	8.5	-	9.5	40	3.5*6*4.5	4.41	6.57
	SRS 15GM	16	32	43	25	20	M3*3.5	25.7	6.5	13.3	3	2.7	15	8.5	-	9.5	40	3.5*6*4.5	5.59	5.72
15N	RSR 15M1V	16	32	43	25	20	M3*4	25.7	-	12	3.5	4	15	8.5	-	9.5	40	3.5*6*4.5	4.41	6.57
	RSR 15N	16	32	60.7	25	25	M3*4	43.5	-	12	3.5	4	15	8.5	-	9.5	40	3.5*6*4.5	7.16	10.7
	SRS 15N	16	32	60.8	25	25	M3*3.5	43.5	6.5	13.3	3	2.7	15	8.5	-	9.5	40	3.5*6*4.5	9.71	8.55
	SRS 15GN	16	32	60.8	25	25	M3*3.5	43.5	6.5	13.3	3	2.7	15	8.5	-	9.5	40	3.5*6*4.5	8.27	11.9
15WS	RSR 15M1N	16	32	61	25	25	M3*4	43.5	-	12	3.5	4	15	8.5	-	9.5	40	3.5*6*4.5	7.16	10.7
	SRS 15WS	16	60	41.5	45	-	M4*4.5	24.9	6.5	13.3	3	2.7	42	9	23	9.5	40	4.5*8*4.5	6.64	5.94
15WM	SRS 15WGS	16	60	41.5	45	-	M4*4.5	24.9	6.5	13.3	3	2.7	42	9	23	9.5	40	4.5*8*4.5	5.59	6.78
	RSR 15WV	16	60	55.5	45	20	M4*4.5	38.9	5.6	12	3.5	4	42	9	23	9.5	40	4.5*8*4.5	6.66	9.8
	RSR 15WVM	16	60	55.5	45	20	M4*4.5	38.9	5.6	12	3.5	4	42	9	23	9.5	40	4.5*8*4.5	6.66	9.8
	SRS 15WM	16	60	55.5	45	20	M4*4.5	38.9	6.5	13.3	3	2.7	42	9	23	9.5	40	4.5*8*4.5	9.12	8.55
	RSR 15WZM	16	60	55.5	45	20	M4*4.5	39.3	5.4	12.6	3	3.4	42	9	23	9.5	40	4.5*8*4.5	6.66	9.8
	SRS 15WGM	16	60	55.5	45	20	M4*4.5	38.9	6.5	13.3	3	2.7	42	9	23	9.5	40	4.5*8*4.5	7.43	8.59
15WN	RSR 15M1WV	16	60	55.5	45	20	M4*4.5	38.9	5.6	12	3.5	4	42	9	23	9.5	40	4.5*8*4.5	6.66	9.8
	RSR 15WN	16	60	74.5	45	35	M4*4.5	57.9	5.6	12	3.5	4	42	9	23	9.5	40	4.5*8*4.5	9.91	14.9
	SRS 15WN	16	60	74.5	45	35	M4*4.5	57.9	6.5	13.3	3	2.7	42	9	23	9.5	40	4.5*8*4.5	12.4	12.1
	SRS 15WGN	16	60	74.5	45	35	M4*4.5	57.9	6.5	13.3	3	2.7	42	9	23	9.5	40	4.5*8*4.5	9.87	15.3
	RSR 15M1WN	16	60	74.5	45	35	M4*4.5	57.9	5.6	12	3.5	4	42	9	23	9.5	40	4.5*8*4.5	9.91	14.9

RSR·SRS Comparison dimensions table

#20/#25

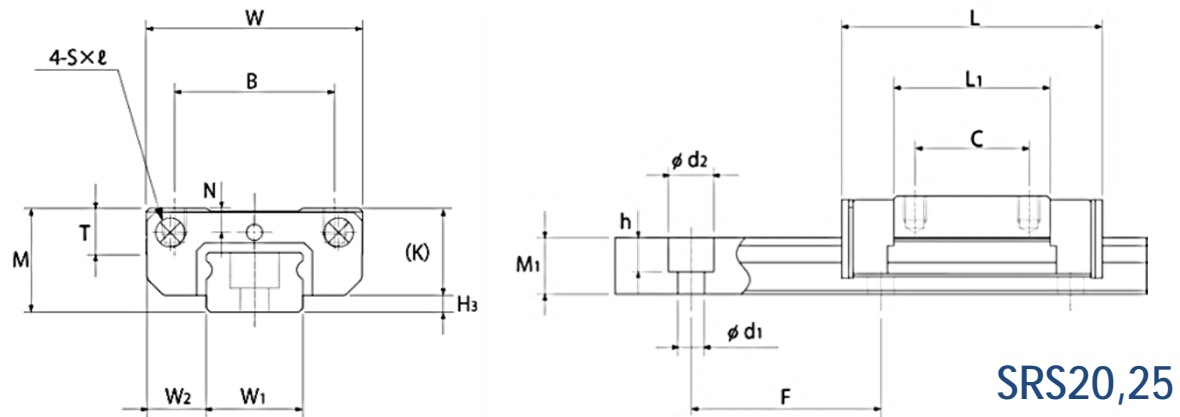

...RSR ...SRS

Block type	Model No.	Outer dimensions			LM block dimensions								LM rail dimensions						Basic load rating	
		Height M	Width W	Length L	B	C	S x l	L1	T	K	N	H3	Width W1	W2	W3	Height M1	Pitch F	d1*d2*h	C kN	C0 kN
20M	RSR 20VM	25	46	66.5	38	38	M4*6	45.2	5.7	17.5	5	7.5	20	13	-	15	60	6*9.5*8.5	8.82	12.7
	SRS 20M	20	40	50	30	25	M4*6	34	9	16.6	4	3.4	20	10	-	11	60	6*9.5*8	7.75	9.77
	SRS 20GM	20	40	50	30	25	M4*6	34	9	16.6	4	3.4	20	10	-	11	60	6*9.5*8	5.95	9.4
20N	RSR 20M1V	25	46	66.5	38	38	M4*6	45.2	5.7	17.5	5	7.5	20	13	-	15	60	6*9.5*8.5	8.82	12.7
	RSR 20N	25	46	86.3	38	38	M4*6	65	5.7	17.5	5	7.5	20	13	-	15	60	6*9.5*8.5	14.2	20.6
25M	RSR 20M1N	25	46	86.3	38	38	M4*6	65	5.7	17.5	5	7.5	20	13	-	15	60	6*9.5*8.5	14.2	20.6
	SRS 25M	25	48	77	35	35	M6*7	56	11	20	5	5	23	12.5	-	15	60	7*11*9	16.5	20.2
	SRS 25GM	25	48	77	35	35	M6*7	56	11	20	5	5	23	12.5	-	15	60	7*11*9	13.3	22.3