

SRG

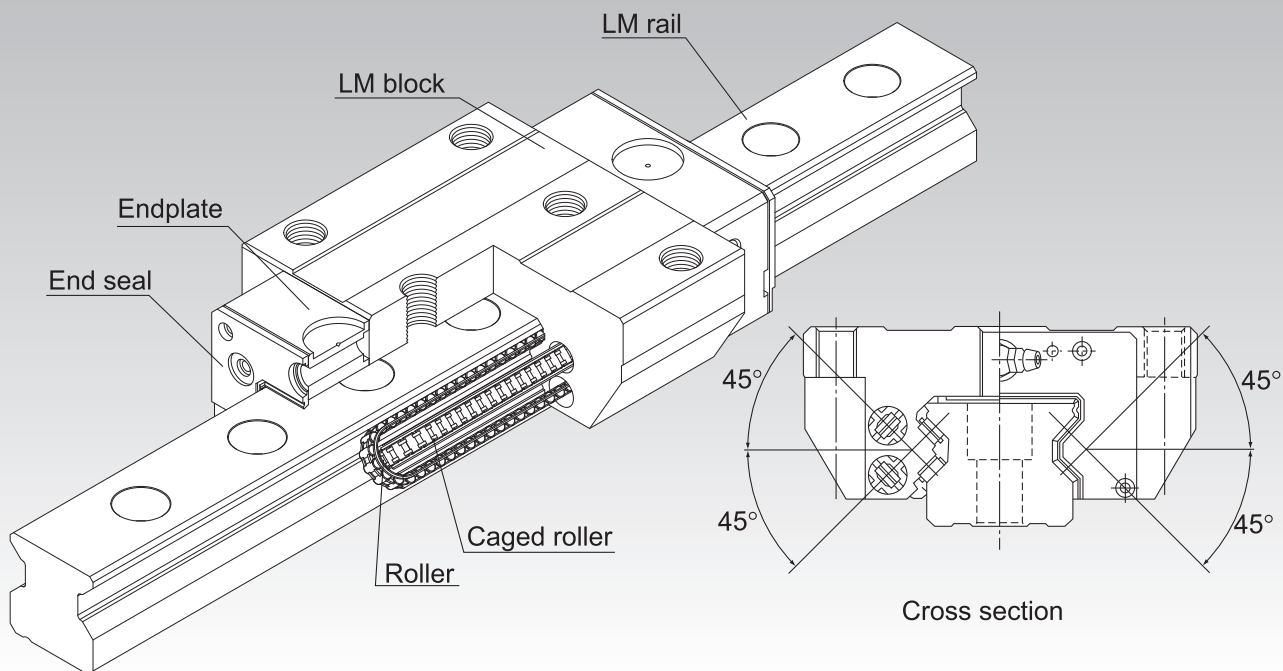

Caged Roller LM Guide Ultra-high Rigidity Type Model SRG



*For the caged roller, see **A1-414**.

Point of Selection	A1-10
Point of Design	A1-460
Options	A1-485
Model No.	A1-551
Precautions on Use	A1-557
Accessories for Lubrication	A24-1
Mounting Procedure and Maintenance	B1-89
Equivalent Moment Factor	A1-43
Rated Loads in All Directions	A1-60
Equivalent Factor in Each Direction	A1-62
Radial Clearance	A1-74
Accuracy Standards	A1-78
Shoulder Height of the Mounting Base and the Corner Radius	A1-472
Reference Error Tolerance for the Mounting Surface	A1-423
Dimensions of Each Model with Options Attached	A1-499

Structure and Features

SRG is an ultra-high rigidity Roller Guide that uses roller cages to allow low-friction, smooth motion and achieve long-term maintenance-free operation.

[Ultra-high Rigidity]

A higher rigidity is achieved by using highly rigid rollers as the rolling elements and having the overall roller length more than 1.5 times greater than the roller diameter.

[4-way Equal Load]

Since each row of rollers is arranged at a contact angle of 45° so that the LM block receives an equal load rating in all four directions (radial, reverse radial and lateral directions), high rigidity is ensured in all directions.

[Smooth Motion through Skewing Prevention]

The roller cage allows rollers to form an evenly spaced line while circulating, thus preventing the rollers from skewing as the block enters an loaded area. As a result, fluctuation of the rolling resistance is minimized, and stable, smooth motion is achieved.

[Long-term Maintenance-free Operation]

Use of roller cages eliminates friction between rollers and increases grease retention, enabling long-term maintenance-free operation to be achieved.

[Global Standard Size]

SRG is designed to have dimensions almost the same as that of Full Ball LM Guide model HSR, which THK as a pioneer of the linear motion system has developed and is practically a global standard size.

[Wide Array of Options]

Various options are available, including end seals, inner seals, side seals, Laminated Contact Scraper LaCS, protectors, side scrapers, High Chemical Resistance Fluorine Seal FS, and GC caps, to accommodate various usage environments.

Types and Features

Models SRG-15XA, 20XA

Specification Table⇒ **A1-424**

The flange of the LM block has tapped holes.
Can be mounted from the top or the bottom.

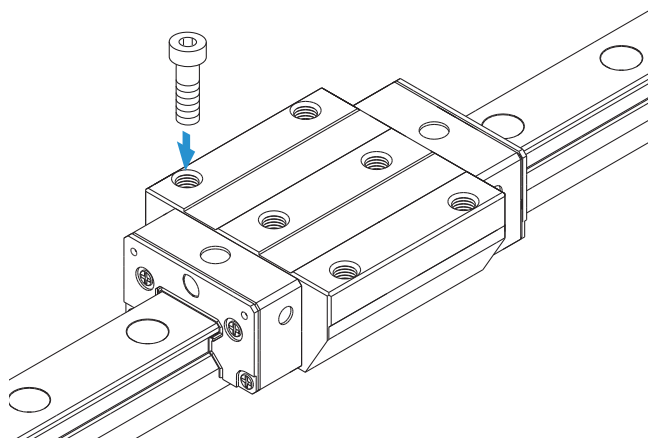

Model SRG-20XLA

Specification Table⇒ **A1-424**

The LM block has the same cross-sectional shape as model SRG-A, but has a longer overall LM block length (L) and a greater rated load.

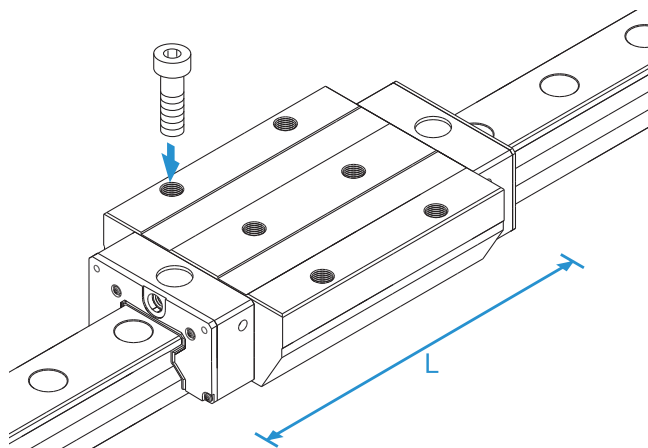

Model SRG-C

The flange of the LM block has tapped holes.
Can be mounted from the top or the bottom.
Used in places where the table cannot have through holes for mounting bolts.

Specification Table⇒ **A1-424**

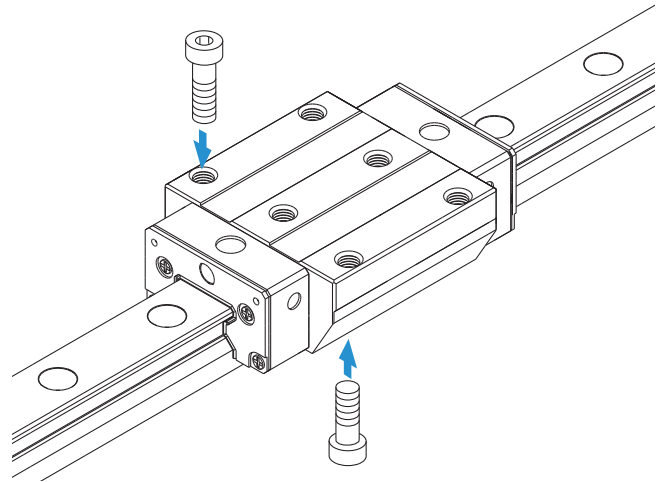

Model SRG-LC

The LM block has the same cross-sectional shape as model SRG-C, but has a longer overall LM block length (L) and a greater rated load.

Specification Table⇒ **A1-424**

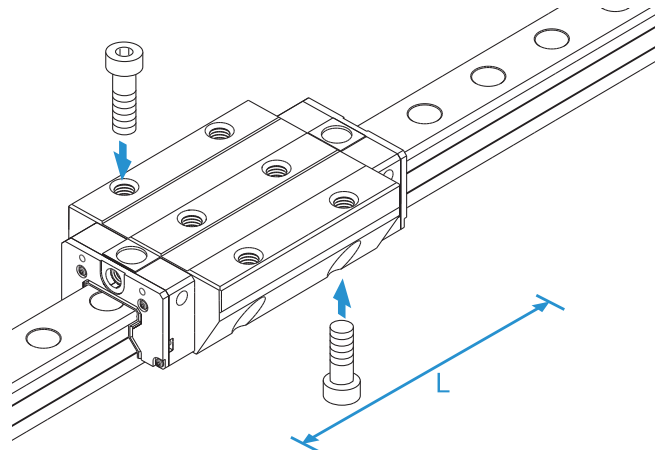

Model SRG-SLC

The LM block has the same cross-sectional shape as model SRG-LC, but has a longer overall LM block length (L) and a greater rated load.

Specification Table⇒ **A1-426**

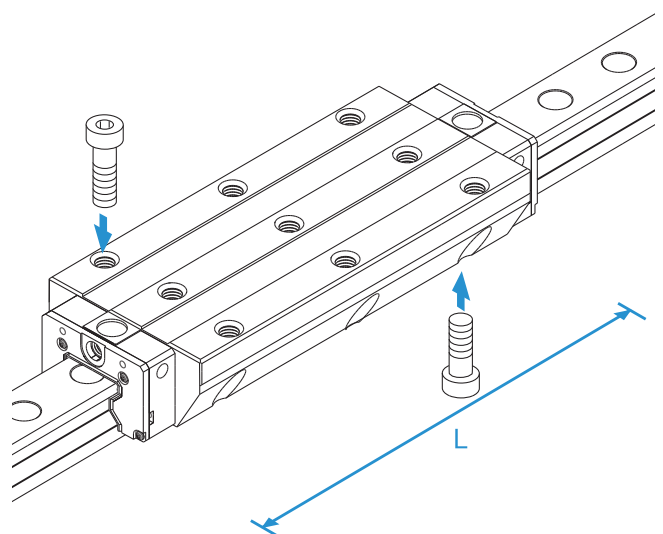

Models SRG-V/R

With this type, the LM block has a smaller width (W) and tapped holes.

Used in places where the space for table width is limited.

Specification Table⇒ **A1-430**

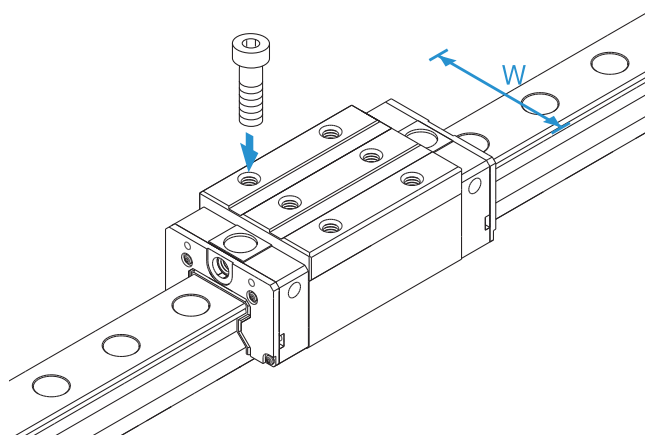

Models SRG-LV/LR

The LM block has the same cross-sectional shape as the Model SRG-V/R, but has a longer overall LM block length (L) and a greater rated load.

Specification Table⇒ **A1-430**

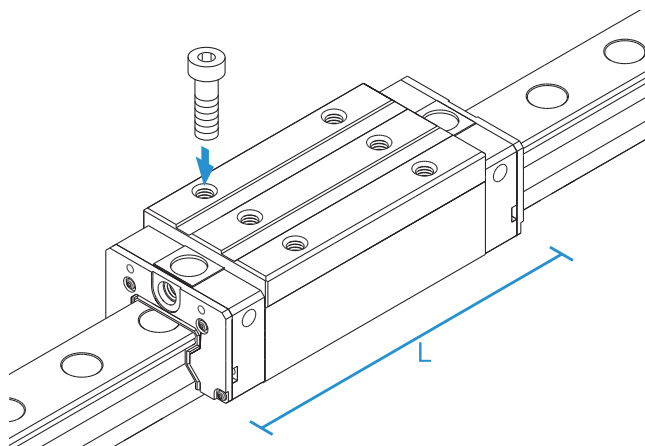

Models SRG-SLV/SLR

The LM block has the same cross-sectional shape as the Model SRG-LV/LR, but has a longer overall LM block length (L) and a greater rated load.

Specification Table⇒ **A1-432**

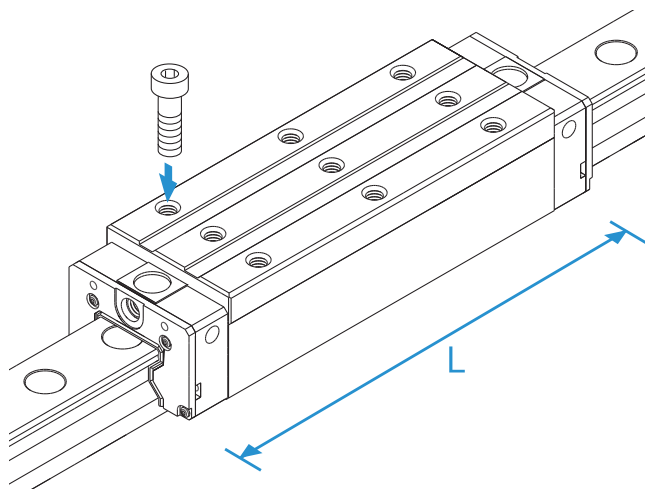

Reference Error Tolerance for the Mounting Surface

The Caged Roller LM Guide Model SRG features high rigidity because it uses rollers as its rolling element, and it also features a roller cage, which prevents the rollers from skewing. However, high machining accuracy is required in the mounting surface. If the error on the mounting surface is large, it will affect the rolling resistance and the service life. The following shows the reference error tolerance according to the radial clearance.

Table1 Reference Horizontal Error Tolerance (P) between Two Rails

Unit: mm

Radial clearance	Normal	C1	C0
Model No.			
SRG 15X	0.005	0.003	0.003
SRG 20X	0.008	0.006	0.004
SRG 25X	0.009	0.007	0.005
SRG 30X	0.011	0.008	0.006
SRG 35	0.014	0.010	0.007
SRG 45	0.017	0.013	0.009
SRG 55	0.021	0.014	0.011
SRG 65	0.027	0.018	0.014
SRG 85	0.040	0.027	0.021
SRG 100	0.045	0.031	0.024

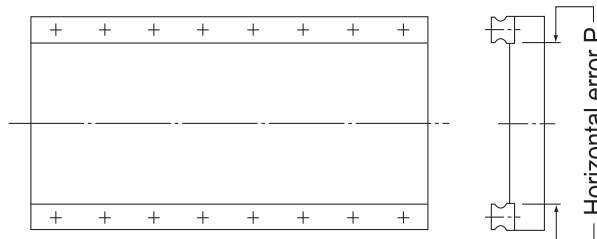

Fig.1

Table2 Reference Vertical Error Tolerance (X) between Two Rails

Unit: mm

Radial clearance	Normal	C1	C0
Reference mounting surface error tolerance X	0.00030a	0.00021a	0.00011a

$X = X_1 + X_2$ X_1 : Level difference on the rail mounting surface

X_2 : Level difference on the block mounting surface

Example of calculation

Rail span when $a = 500\text{mm}$

Reference mounting surface error tolerance $X = 0.0003 \times 500 = 0.15$

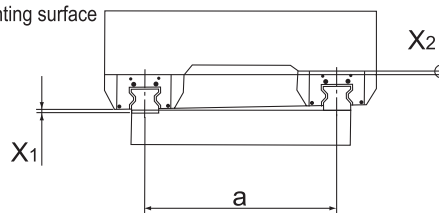

Fig.2

Table3 Reference Vertical Error Tolerance (Y) in the Axial Direction

Unit: mm

Reference mounting surface error tolerance	0.000036b
--	-----------

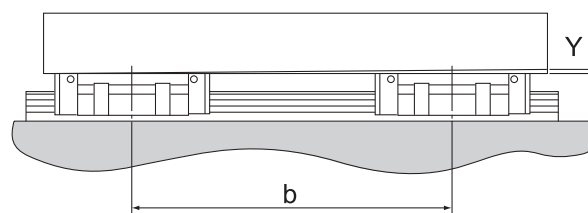
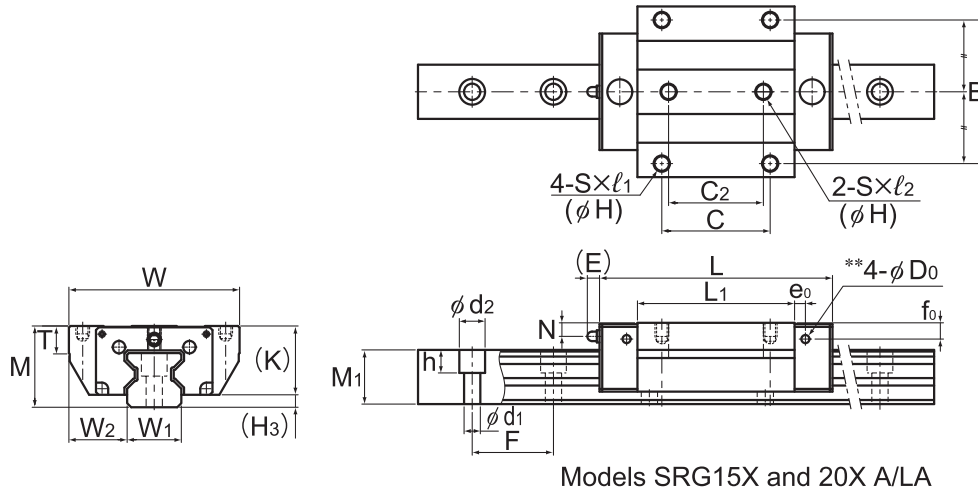

Fig.3

Models SRG-A, SRG-LA, SRG-C and SRG-LC



Models SRG15X and 20X A/LA

Model No.	Outer dimensions			LM block dimensions																	Grease nipple
	Height	Width	Length	B	C	C ₂	S	H*	l ₁	l ₂	L ₁	T	T ₁ *	K	N	E	e ₀	f ₀	D ₀		
	M	W	L	B	C	C ₂	S	H*	l ₁	l ₂	L ₁	T	T ₁ *	K	N	E	e ₀	f ₀	D ₀		
SRG 15XA	24	47	69.2	38	30	26	M5	(4.3)	8	7.5	45	7	(8)	20	4	4.5	4	6	2.9	PB107	
SRG 20XA SRG 20XLA	30	63	86.2 106.2	53	40	35	M6	(5.4)	10	9	58 78	10	(10)	25.4	5	4.5	4	6	2.9	PB107	
SRG 25XC SRG 25XLC	36	70	95.1 115.1	57	45	40	M8	6.8	—	—	65.5 85.5	9.5	10	31.5	5.5	12	6	7.3	5.2	B-M6F	
SRG 30XC SRG 30XLC	42	90	111 135	72	52	44	M10	8.5	—	—	75 99	12	14	37	6.5	12	6	7.5	5.2	B-M6F	

Model number coding

SRG30X	LC	2	QZ	TTHH	C0	+1200L	P	Z	T	-II
Model number	Type of LM block	No. of LM blocks used on the same rail	With QZ Lubricator	Contamination protection accessory symbol (*1)	Radial clearance symbol (*2)	LM rail length (in mm)	Accuracy symbol (*3)	With plate cover	Symbol for LM rail jointed use	Symbol for No. of rails used on the same plane (*4)
				Normal (No symbol) Light preload (C1) Medium preload (C0)			High accuracy grade (H)/Precision grade (P) Super precision grade (SP)/Ultra precision grade (UP)			

(*1) See contamination protection accessory on **A1-524**. (*2) See **A1-74**. (*3) See **A1-78**. (*4) See **A1-13**.

Note) This model number indicates that a single-rail unit constitutes one set. (i.e., required number of sets when 2 rails are used in parallel is 2 at a minimum.)

Those models equipped with QZ Lubricator cannot have a grease nipple. When desiring a grease nipple for a model attached with QZ, contact THK.

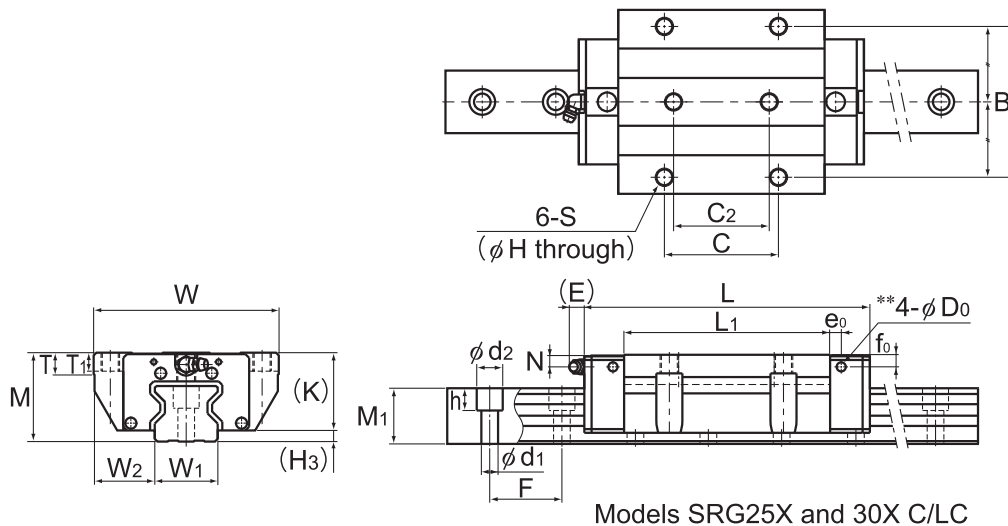

Models SRG25X and 30X C/LC

Unit: mm

	LM rail dimensions						Basic load rating*		Static permissible moment kN·m*					Mass	
	H ₃	Width	Height	Pitch	Length*	C	C ₀	M _A		M _B		M _C	LM block	LM rail	
		W ₁ 0 -0.05						W ₂	M ₁	F	d ₁ × d ₂ × h				Max
4	15	16	15.5	30	4.5 × 7.5 × 5.3	3000	11.3	25.8	0.21	1.24	0.21	1.24	0.24	0.2	1.58
4.6	20	21.5	20	30	6 × 9.5 × 8.5	3000	21 26.7	46.9 63.8	0.48 0.88	2.74 4.49	0.48 0.88	2.74 4.49	0.58 0.79	0.42 0.57	2.58
4.5	23	23.5	23	30	7 × 11 × 9	3000	27.9 34.2	57.5 75	0.64 1.07	3.7 5.74	0.64 1.07	3.7 5.74	0.8 1.03	0.7 0.9	3.6
5	28	31	26	40	9 × 14 × 12	3000	39.3 48.3	82.5 108	1.02 1.76	6.21 9.73	1.02 1.76	6.21 9.73	1.47 1.92	1.2 1.6	4.4

Note1) The maximum length under "Length*" indicates the standard maximum length of an LM rail. (See [A1-434](#).)

Static permissible moment* 1 block: the static permissible moment with one LM block

Double blocks: static permissible moment when two LM blocks are in close contact with each other

For oil lubrication, be certain to let THK know the mounting orientation and where the LM block piping joint should be attached.

(Mounting orientation: see [A1-12](#), Lubricant: see [A24-2](#))

Total block length L : The total block length L shown in the table is the length with the dust proof parts, code UU or SS. If other contamination protection accessories or lubricant equipment are installed, the total block length will increase.

(See [A1-499](#) or [A1-520](#))

The removing/mounting jig is not provided as standard. Contact THK before use.

** A pilot hole for side nipples, when a grease nipple for a model equipped with LaCS or QZ Lubricator is needed.

Pilot holes for side nipples are not drilled through for models other than those stated above.

For grease nipple mount machining, contact THK. (See [A1-436](#))

Note2) H*, T₁* If the mounting holes (4 holes) of the LM block are back spot-faced, these models can be mounted on the table from the top and the bottom as with the Model SRG-C.

The value in the parentheses represents a dimension if the mounting hole is back spot-faced.

Contact THK for details.

Note3) The basic dynamic load rating of the roller guide is a value based on a nominal life of 100 km.

The conversion to basic dynamic load rating for a nominal life of 50 km can be obtained from the following equation.

$$C_{50} = C \times 1.23$$

C₅₀ : The basic dynamic load rating for a nominal load of 50 km

C : The basic dynamic load rating in the dimensional table

Models SRG-C, SRG-LC and SRG-SLC

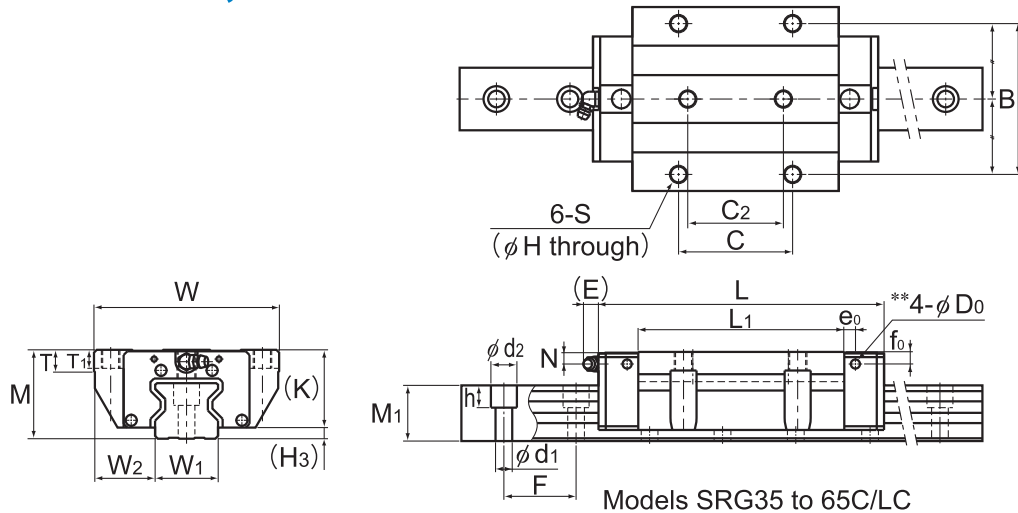

Model No.	Outer dimensions			LM block dimensions																Grease nipple
	Height	Width	Length	B	C	C ₂	S	H	ℓ ₁	ℓ ₂	L ₁	T	T ₁	K	N	E	e ₀	f ₀	D ₀	
	M	W	L																	
SRG 35C SRG 35LC SRG 35SLC	48	100	125 155 180.8	82	62	52	M10	8.5	—	—	82.2 112.2 138	11.5	10	42	6.5	12	6	6	5.2	B-M6F
SRG 45C SRG 45LC SRG 45SLC	60	120	155 190 231.5	100	80	60	M12	10.5	—	—	107 142 183.5	14.5	15	52	10	16	7	7	5.2	B-PT1/8
SRG 55C SRG 55LC SRG 55SLC	70	140	185 235 292	116	95	70	M14	12.5	—	—	129.2 179.2 236.2	17.5	18	60	12	16	9	8.5	5.2	B-PT1/8
SRG 65C SRG 65LC SRG 65SLC	90	170	244.9 303 380	142	110 110 200	82	M16	14.5	—	—	171.7 229.8 306.8	19.5	20	78.5	17	16	9	13.5	5.2	B-PT1/8

Model number coding

SRG45	LC	2	QZ	TTHH	C0	+1200L	P	Z	T	-II
Model number	Type of LM block	No. of LM blocks used on the same rail	With QZ Lubricator	Contamination protection accessory symbol (*1)	Radial clearance symbol (*2) Normal (No symbol) Light preload (C1) Medium preload (C0)	LM rail length (in mm)	Accuracy symbol (*3) High accuracy grade (H)/Precision grade (P) Super precision grade (SP)/Ultra precision grade (UP)	With plate cover	Symbol for LM rail jointed use	Symbol for No. of rails used on the same plane (*4)

(*1) See contamination protection accessory on **A1-524**. (*2) See **A1-74**. (*3) See **A1-78**. (*4) See **A1-13**.

Note) This model number indicates that a single-rail unit constitutes one set. (i.e., required number of sets when 2 rails are used in parallel is 2 at a minimum.)

Those models equipped with QZ Lubricator cannot have a grease nipple. When desiring a grease nipple for a model attached with QZ, contact THK.

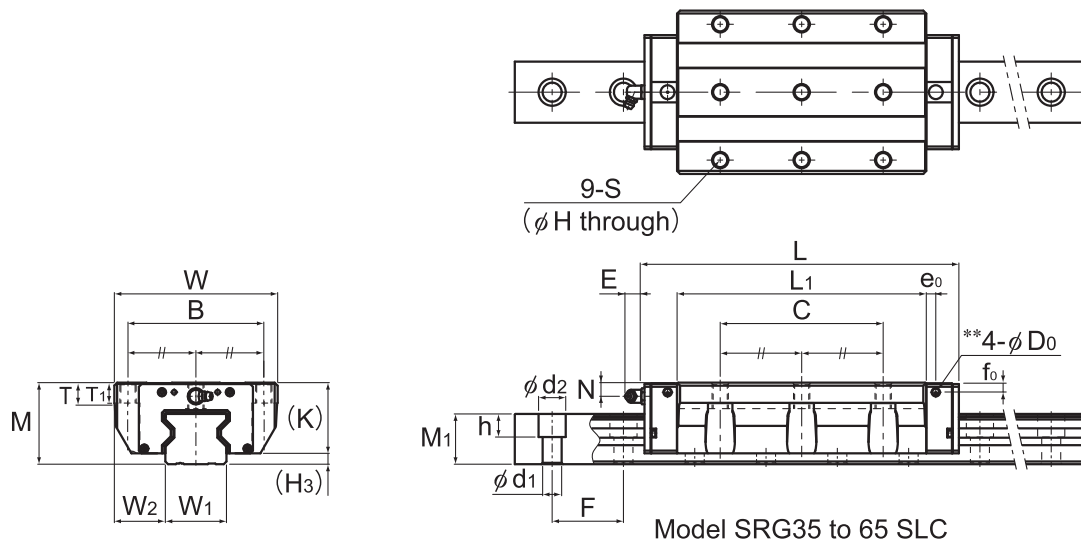

Unit: mm

H ₃	LM rail dimensions							Basic load rating*		Static permissible moment kN·m*					Mass	
	Width W ₁ 0 -0.05	W ₂	Height M ₁	Pitch F	Pitch F	Length* d ₁ × d ₂ × h Max	C	C ₀	M _A		M _B		M _C	LM block	LM rail	
									1 block	Double blocks	1 block	Double blocks	1 block	kg	kg/m	
6	34	33	30	40	9 × 14 × 12	3000	59.1 76 87.9	119 165 199	1.66 3.13 4.53	10.1 17 23.9	1.66 3.13 4.53	10.1 17 23.9	2.39 3.31 4.09	1.9 2.4 3.2	6.9	
8	45	37.5	37	52.5	14 × 20 × 17	3090	91.9 115 139	192 256 328	3.49 6.13 9.99	20 32.2 50	3.49 6.13 9.99	20 32.2 50	4.98 6.64 8.91	3.7 4.5 6.3	11.6	
10	53	43.5	43	60	16 × 23 × 20	3060	131 167 210	266 366 488	5.82 10.8 19.1	33 57 93.7	5.82 10.8 19.1	33 57 93.7	8.19 11.2 15.6	5.9 7.8 10.7	15.8	
11.5	63	53.5	54	75	18 × 26 × 22	3000	219 278 352	441 599 811	12.5 22.7 41.3	72.8 120 202	12.5 22.7 41.3	72.8 120 202	16.8 22.1 30.9	12.5 16.4 22.3	23.7	

Note1) The maximum length under "Length*" indicates the standard maximum length of an LM rail. (See [A1-434](#).)

Static permissible moment* 1 block: the static permissible moment with one LM block

Double blocks: static permissible moment when two LM blocks are in close contact with each other

For oil lubrication, be certain to let THK know the mounting orientation and where the LM block piping joint should be attached.

(Mounting orientation: see [A1-12](#), Lubricant: see [A24-2](#))

Total block length L : The total block length L shown in the table is the length with the dust proof parts, code UU or SS. If other contamination protection accessories or lubricant equipment are installed, the total block length will increase.

(See [A1-499](#) or [A1-520](#))

The removing/mounting jig is not provided as standard. Contact THK before use.

** A pilot hole for side nipples, when a grease nipple for a model equipped with LaCS or QZ Lubricator is needed.

Pilot holes for side nipples are not drilled through for models other than those stated above.

For grease nipple mount machining, contact THK. (See [A1-436](#))

Note2) The basic dynamic load rating of the roller guide is a value based on a nominal life of 100 km.

The conversion to basic dynamic load rating for a nominal life of 50 km can be obtained from the following equation.

$$C_{50} = C \times 1.23$$

C₅₀ : The basic dynamic load rating for a nominal load of 50 km

C : The basic dynamic load rating in the dimensional table

Model SRG-LC

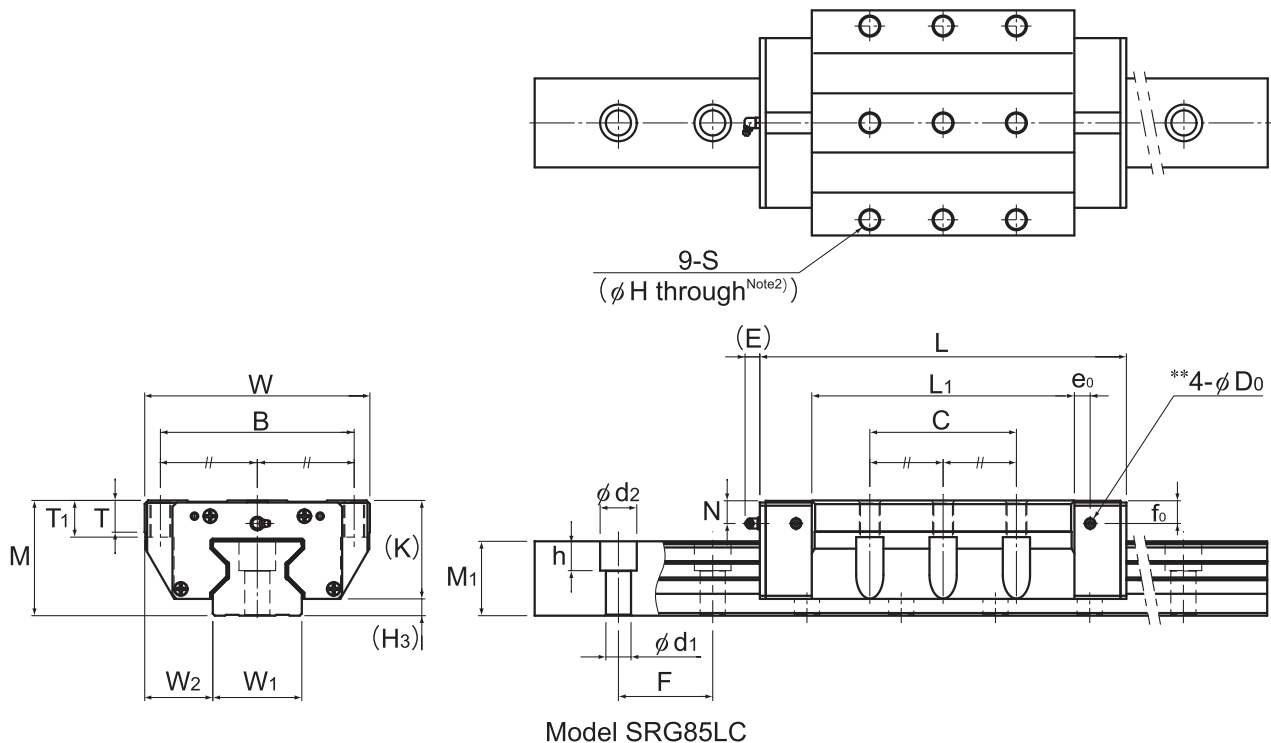

Model No.	Outer dimensions			LM block dimensions													Grease nipple
	Height	Width	Length	B	C	S	H	L ₁	T	T ₁	K	N	E	e ₀	f ₀	D ₀	
	M	W	L														
SRG 85LC	110	215	350	185	140	M20	17.8	250.8	30	35	94	22	16	15	22	8.2	B-PT1/8
SRG 100LC	120	250	395	220	200	M20	17.8	280.2	35	38	104	23	16	15	23	8.2	B-PT1/4

Model number coding

SRG85 LC 2 TT C0 +2610L P Z T - II

Model number

Type of LM block

Contamination protection accessory symbol (*1)

LM rail length (in mm)

With plate cover

Symbol for No. of rails used on the same plane (*4)

No. of LM blocks used on the same rail

Radial clearance symbol (*2)
Normal (No symbol)
Light preload (C1)
Medium preload (C0)

Symbol for LM rail jointed use

Accuracy symbol (*3)
Precision grade (P)/Super precision grade (SP)
Ultra precision grade (UP)

(*1) See contamination protection accessory on **A1-524**. (*2) See **A1-74**. (*3) See **A1-78**. (*4) See **A1-13**.

Note) This model number indicates that a single-rail unit constitutes one set. (i.e., required number of sets when 2 rails are used in parallel is 2 at a minimum.)

Those models equipped with QZ Lubricator cannot have a grease nipple. When desiring a grease nipple for a model attached with QZ, contact THK.

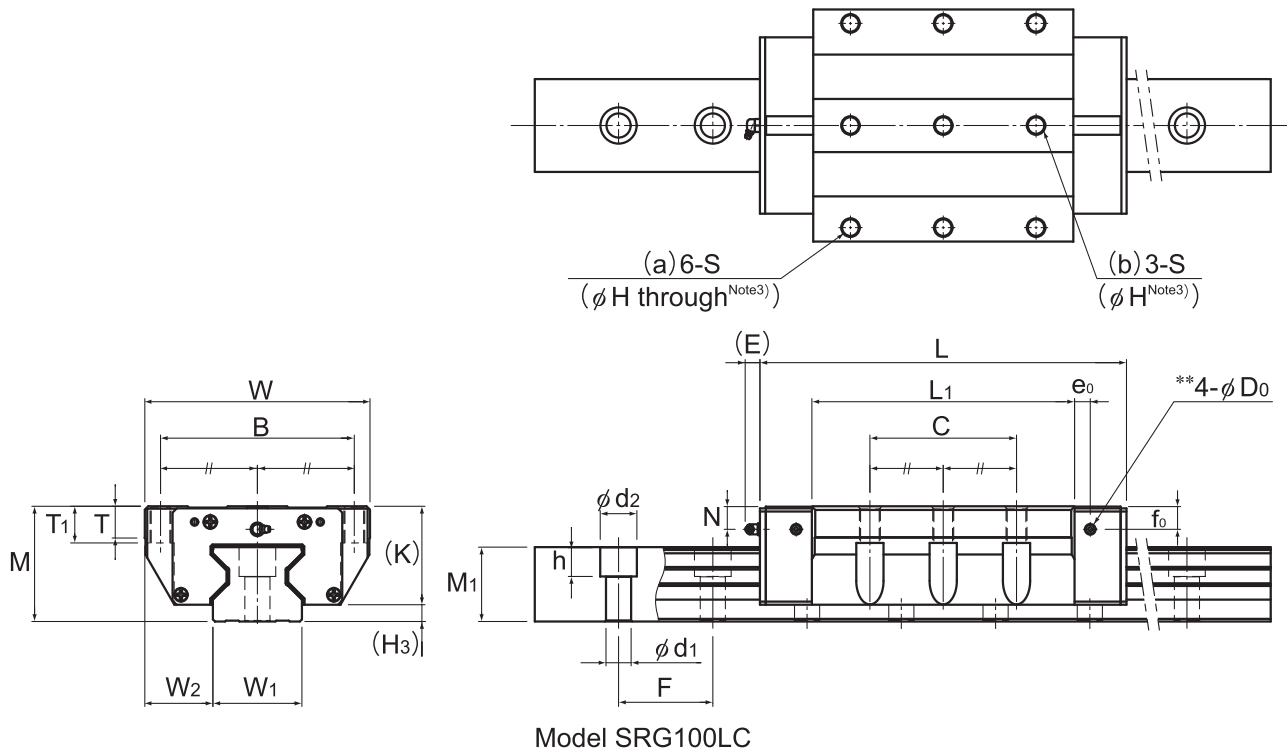

Unit: mm

H ₃	LM rail dimensions						Basic load rating*			Static permissible moment kN·m*					Mass	
	Width	W ₁ 0 -0.05	W ₂	Height	Pitch	Length* Max	C kN	C ₀ kN	M _A		M _B		M _C	LM block	LM rail	
	M ₁			F	d ₁ × d ₂ × h				1 block	Double blocks	1 block	Double blocks	1 block	kg	kg/m	
16	85	65	71	90	24 × 35 × 28	3000	497	990	45.3	239	45.3	239	51.9	26.2	35.7	
16	100	75	77	105	26 × 39 × 32	3000	601	1170	60	319	60	319	72.3	37.6	46.8	

Note1) The maximum length under "Length*" indicates the standard maximum length of an LM rail. (See **A1-434**.)

Static permissible moment* 1 block: the static permissible moment with one LM block

Double blocks: static permissible moment when two LM blocks are in close contact with each other

For oil lubrication, be certain to let THK know the mounting orientation and where the LM block piping joint should be attached.

(Mounting orientation: see **A1-12**, Lubricant: see **A24-2**)

Total block length L : The total block length L shown in the table is the length with the dust proof parts, code UU or SS. If other contamination protection accessories or lubricant equipment are installed, the total block length will increase.

(See **A1-499** or **A1-520**)

The removing/mounting jig is not provided as standard. Contact THK before use.

** A pilot hole for side nipples, when a grease nipple for a model equipped with LaCS or QZ Lubricator is needed.

Pilot holes for side nipples are not drilled through for models other than those stated above.

For grease nipple mount machining, contact THK. (See **A1-436**)

Note2) The LM block mounting holes (9 holes) of SRG85LC are all through holes (full thread).

Note3) The LM block mounting holes in part (a) (6 holes) of SRG100LC are through holes (full thread).

The LM block mounting holes in part (b) (3 holes) have effective thread depth of 22 mm.

Note4) The basic dynamic load rating of the roller guide is a value based on a nominal life of 100 km.

The conversion to basic dynamic load rating for a nominal life of 50 km can be obtained from the following equation.

$$C_{50} = C \times 1.23$$

C₅₀ : The basic dynamic load rating for a nominal load of 50 km

C : The basic dynamic load rating in the dimensional table

Models SRG-V, SRG-LV, SRG-R and SRG-LR

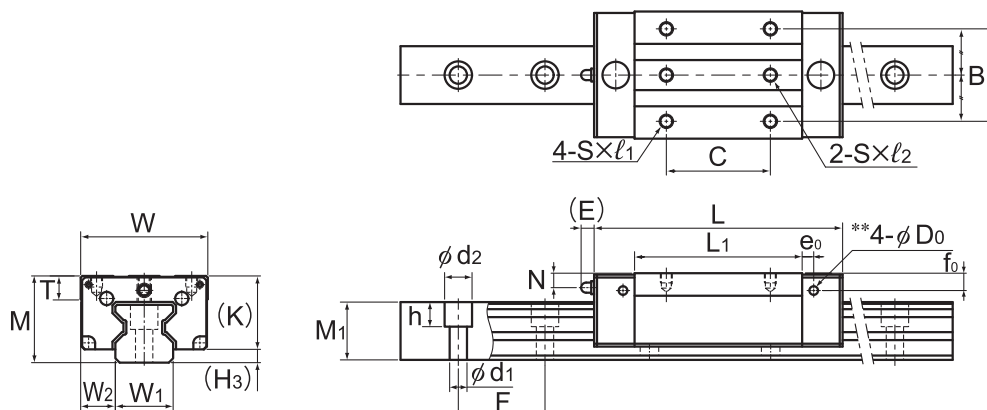

Models SRG15X and 20X V/LV

Model No.	Outer dimensions			LM block dimensions															Grease nipple
	Height	Width	Length	B	C	S	ℓ	ℓ_1	ℓ_2	L_1	T	K	N	E	e_0	f_0	D_0		
	M	W	L																
SRG 15XV	24	34	69.2	26	26	M4	—	5	7.5	45	6	20	4	4.5	4	6	2.9	PB107	
SRG 20XV SRG 20XLV	30	44	86.2 106.2	32	36 50	M5	—	7	9	58 78	8	25.4	5	4.5	4	6	2.9	PB107	
SRG 25XR SRG 25XLR	40	48	95.1 115.1	35	35 50	M6	9	—	—	65.5 85.5	9.5	35.5	9.5	12	6	11.3	5.2	B-M6F	
SRG 30XR SRG 30XLR	45	60	111 135	40	40 60	M8	10	—	—	75 99	12	40	9.5	12	6	10.5	5.2	B-M6F	

Model number coding

SRG30X	LR	2	QZ	TTHH	C0	+1200L	P	Z	T	-II
Model number	Type of LM block	No. of LM blocks used on the same rail	With QZ Lubricator	Contamination protection accessory symbol (*1)	Radial clearance symbol (*2) Normal (No symbol) Light preload (C1) Medium preload (C0)	LM rail length (in mm)	Accuracy symbol (*3) High accuracy grade (H)/Precision grade (P) Super precision grade (SP)/Ultra precision grade (UP)	With plate cover	Symbol for LM rail jointed use	Symbol for No. of rails used on the same plane (*4)

(*1) See contamination protection accessory on **A1-524**. (*2) See **A1-74**. (*3) See **A1-78**. (*4) See **A1-13**.

Note) This model number indicates that a single-rail unit constitutes one set. (i.e., required number of sets when 2 rails are used in parallel is 2 at a minimum.)

Those models equipped with QZ Lubricator cannot have a grease nipple. When desiring a grease nipple for a model attached with QZ, contact THK.

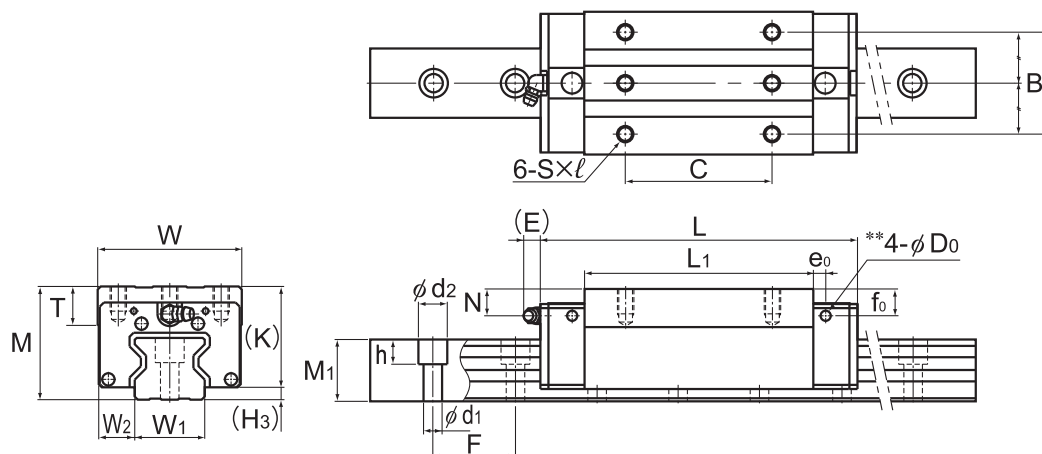

Models SRG25X and 30X R/LR

Unit: mm

	LM rail dimensions							Basic load rating*		Static permissible moment kN·m*					Mass	
	Width W ₁ 0 -0.05	Height M ₁	Pitch F	Length* Max	d ₁ × d ₂ × h	C	C ₀	M _A		M _B		M _C	LM block	LM rail		
								1 block	Double blocks	1 block	Double blocks	1 block	kg	kg/m		
4	15	9.5	15.5	30	4.5 × 7.5 × 5.3	3000	11.3	25.8	0.21	1.24	0.21	1.24	0.24	0.15	1.58	
4.6	20	12	20	30	6 × 9.5 × 8.5	3000	21 26.7	46.9 63.8	0.48 0.88	2.74 4.49	0.48 0.88	2.74 4.49	0.58 0.79	0.28 0.38	2.58	
4.5	23	12.5	23	30	7 × 11 × 9	3000	27.9 34.2	57.5 75	0.64 1.07	3.7 5.74	0.64 1.07	3.7 5.74	0.8 1.03	0.6 0.8	3.6	
5	28	16	26	40	9 × 14 × 12	3000	39.3 48.3	82.5 108	1.02 1.76	6.21 9.73	1.02 1.76	6.21 9.73	1.47 1.92	0.9 1.2	4.4	

Note1) The maximum length under "Length*" indicates the standard maximum length of an LM rail. (See **A1-434**.)

Static permissible moment* 1 block: the static permissible moment with one LM block

Double blocks: static permissible moment when two LM blocks are in close contact with each other

For oil lubrication, be certain to let THK know the mounting orientation and where the LM block piping joint should be attached.

(Mounting orientation: see **A1-12**, Lubricant: see **A24-2**)

Total block length L : The total block length L shown in the table is the length with the dust proof parts, code UU or SS. If other contamination protection accessories or lubricant equipment are installed, the total block length will increase.

(See **A1-499** or **A1-520**)

The removing/mounting jig is not provided as standard. Contact THK before use.

** A pilot hole for side nipples, when a grease nipple for a model equipped with LaCS or QZ Lubricator is needed.

Pilot holes for side nipples are not drilled through for models other than those stated above.

For grease nipple mount machining, contact THK. (See **A1-436**)

Note2) The basic dynamic load rating of the roller guide is a value based on a nominal life of 100 km.

The conversion to basic dynamic load rating for a nominal life of 50 km can be obtained from the following equation.

$$C_{50} = C \times 1.23$$

C_{50} : The basic dynamic load rating for a nominal load of 50 km

C : The basic dynamic load rating in the dimensional table

Models SRG-V, SRG-LV, SRG-SLV, SRG-R, SRG-LR and SRG-SLR

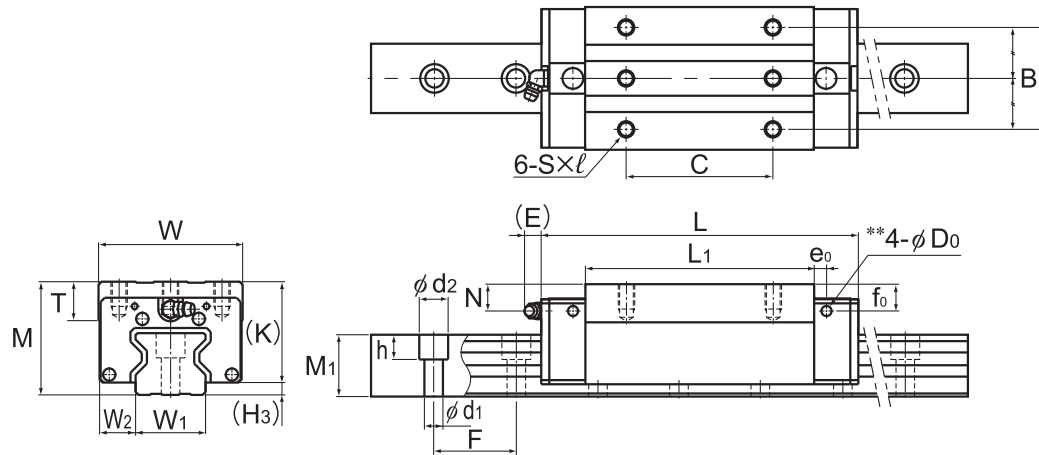

Models SRG35 to 65R/LR/LV

Model No.	Outer dimensions			LM block dimensions														Grease nipple
	Height	Width	Length	B	C	S	ℓ	ℓ ₁	ℓ ₂	L ₁	T	K	N	E	e ₀	f ₀	D ₀	
	M	W	L															
SRG 35R SRG 35LR SRG 35SLR	55	70	125 155 180.8	50	72 100	M8	12	—	—	82.2 112.2 138	18.5	49	13.5	12	6	13	5.2	B-M6F
SRG 45R SRG 45LR SRG 45SLR	70	86	155 190 231.5	60	80 120	M10	20	—	—	107 142 183.5	24.5	62	20	16	7	17	5.2	B-PT1/8
SRG 55R SRG 55LR SRG 55SLR	80	100	185 235 292	75	95 150	M12	18	—	—	129.2 179.2 236.2	27.5	70	22	16	9	18.5	5.2	B-PT1/8
SRG 65V SRG 65LV SRG 65SLV	90	126	244.9 303 380	76	70 120 200	M16	20	—	—	171.7 229.8 306.8	19.5	78.5	17	16	9	13.5	5.2	B-PT1/8

Model number coding

SRG45	LR	2	QZ	TTHH	C0	+1200L	P	Z	T	- II
Model number	Type of LM block	No. of LM blocks used on the same rail	With QZ Lubricator	Contamination protection accessory symbol (*1)	Radial clearance symbol (*2) Normal (No symbol) Light preload (C1) Medium preload (C0)	LM rail length (in mm)	Accuracy symbol (*3) High accuracy grade (H)/Precision grade (P) Super precision grade (SP)/Ultra precision grade (UP)	With plate cover	Symbol for LM rail jointed use	Symbol for No. of rails used on the same plane (*4)

(*1) See contamination protection accessory on **A1-524**. (*2) See **A1-74**. (*3) See **A1-78**. (*4) See **A1-13**.

Note) This model number indicates that a single-rail unit constitutes one set. (i.e., required number of sets when 2 rails are used in parallel is 2 at a minimum.)

Those models equipped with QZ Lubricator cannot have a grease nipple. When desiring a grease nipple for a model attached with QZ, contact THK.

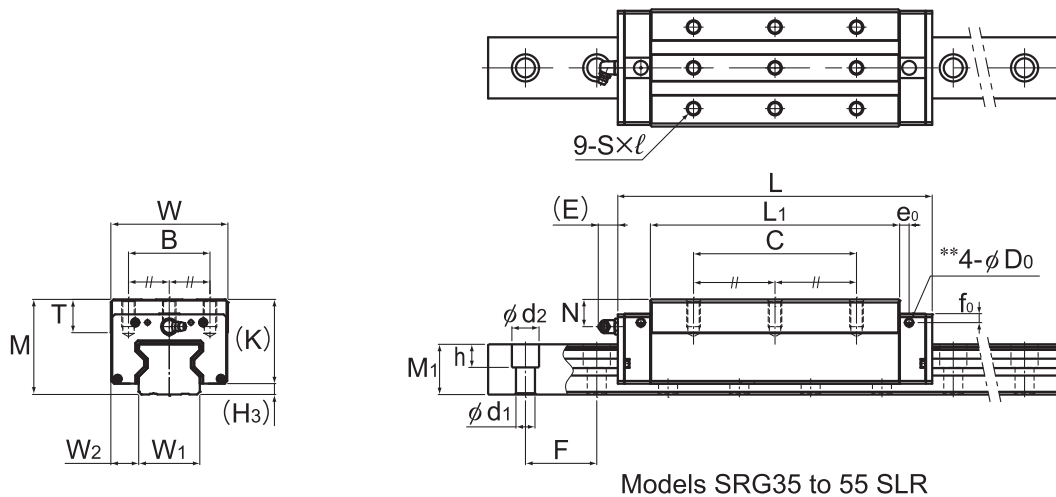

Models SRG35 to 55 SLR

Unit: mm

	LM rail dimensions							Basic load rating*		Static permissible moment kN·m*					Mass	
	H ₃	Width	Height	Pitch	Length*	Length*	C	C ₀	M _A		M _B		M _C	LM block	LM rail	
		W ₁ 0 -0.05							W ₂	M ₁	F	d ₁ × d ₂ × h	Max	kN	kN	1 block
6	34	18	30	40	9 × 14 × 12	3000	59.1 76 87.9	119 165 199	1.66 3.13 4.53	10.1 17 23.9	1.66 3.13 4.53	10.1 17 23.9	2.39 3.31 4.09	1.6 2.1 2.6	6.9	
8	45	20.5	37	52.5	14 × 20 × 17	3090	91.9 115 139	192 256 328	3.49 6.13 9.99	20 32.2 50	3.49 6.13 9.99	20 32.2 50	4.98 6.64 8.91	3.2 4.1 5.4	11.6	
10	53	23.5	43	60	16 × 23 × 20	3060	131 167 210	266 366 488	5.82 10.8 19.1	33 57 93.7	5.82 10.8 19.1	33 57 93.7	8.19 11.2 15.6	5 6.9 9.2	15.8	
11.5	63	31.5	54	75	18 × 26 × 22	3000	219 278 352	441 599 811	12.5 22.7 41.3	72.8 120 202	12.5 22.7 41.3	72.8 120 202	16.8 22.1 30.9	9.0 12.1 16.1	23.7	

Note1) The maximum length under "Length*" indicates the standard maximum length of an LM rail. (See [A1-434](#).)

Static permissible moment* 1 block: the static permissible moment with one LM block

Double blocks: static permissible moment when two LM blocks are in close contact with each other

For oil lubrication, be certain to let THK know the mounting orientation and where the LM block piping joint should be attached.

(Mounting orientation: see [A1-12](#), Lubricant: see [A24-2](#))

Total block length L : The total block length L shown in the table is the length with the dust proof parts, code UU or SS. If other contamination protection accessories or lubricant equipment are installed, the total block length will increase.

(See [A1-499](#) or [A1-520](#))

The removing/mounting jig is not provided as standard. Contact THK before use.

** A pilot hole for side nipples, when a grease nipple for a model equipped with LaCS or QZ Lubricator is needed.

Pilot holes for side nipples are not drilled through for models other than those stated above.

For grease nipple mount machining, contact THK. (See [A1-436](#))

Note2) The basic dynamic load rating of the roller guide is a value based on a nominal life of 100 km.

The conversion to basic dynamic load rating for a nominal life of 50 km can be obtained from the following equation.

$$C_{50} = C \times 1.23$$

C₅₀ : The basic dynamic load rating for a nominal load of 50 km

C : The basic dynamic load rating in the dimensional table

Standard Length and Maximum Length of the LM Rail

Table4 shows the standard lengths and the maximum lengths of model SRG variations. If the maximum length of the desired LM rail exceeds them, jointed rails will be used. Contact THK for details. For special rail lengths, it is recommended to use a value corresponding to the G,g dimension from the table. As the G,g dimension increases, this portion becomes less stable, and the accuracy performance is severely impacted.

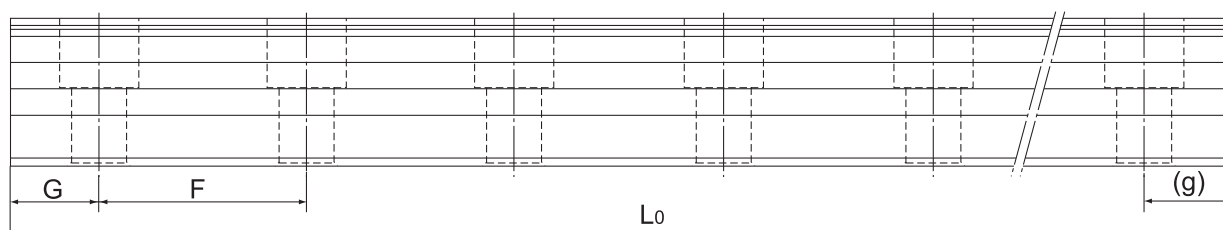

Table4 Standard Length and Maximum Length of the LM Rail for Model SRG

Unit: mm

Model No.	SRG 15X	SRG 20X	SRG 25X	SRG 30X	SRG 35	SRG 45	SRG 55	SRG 65	SRG 85	SRG 100
LM rail standard length (L_0)	160	220	220	280	280	570	780	1270	1530	1340
	220	280	280	360	360	675	900	1570	1890	1760
	280	340	340	440	440	780	1020	2020	2250	2180
	340	400	400	520	520	885	1140	2620	2610	2600
	400	460	460	600	600	990	1260			
	460	520	520	680	680	1095	1380			
	520	580	580	760	760	1200	1500			
	580	640	640	840	840	1305	1620			
	640	700	700	920	920	1410	1740			
	700	760	760	1000	1000	1515	1860			
	760	820	820	1080	1080	1620	1980			
	820	880	880	1160	1160	1725	2100			
	880	940	940	1240	1240	1830	2220			
	940	1000	1000	1320	1320	1935	2340			
	1000	1060	1060	1400	1400	2040	2460			
	1060	1120	1120	1480	1480	2145	2580			
	1120	1180	1180	1560	1560	2250	2700			
	1180	1240	1240	1640	1640	2355	2820			
	1240	1300	1300	1720	1720	2460	2940			
	1300	1360	1360	1800	1800	2565	3060			
1360	1420	1420	1880	1880	2670					
1420	1480	1480	1960	1960	2775					
1480	1540	1540	2040	2040	2880					
1540	1600	1600	2120	2120	2985					
1600	1660	1660	2200	2200	3090					
1660	1720	1720	2280	2280						
1720	1780	1780	2360	2360						
1780	1840	1840	2440	2440						
1840	1900	1900								
1900	1960	1960								
1960	2020	2020								
2020	2080	2080								
2080	2140	2140								
2140	2200	2200								
2200	2260	2260								
2260	2320	2320								
2320	2380	2380								
2380	2440	2440								
2440										
Standard pitch F	30	30	30	40	40	52.5	60	75	90	105
G,g	20	20	20	20	20	22.5	30	35	45	40
Max length	3000	3000	3000	3000	3000	3090	3060	3000	3000	3000

Note1) The maximum length varies with accuracy grades. Contact THK for details.

Note2) If jointed rails are not allowed and a greater length than the maximum values above is required, contact THK.

Plate Cover

By covering the LM rail's mounting holes with ultra-thin stainless steel (SUS304) plates, the sealability of the end seals increase drastically, helping prevent foreign materials and liquid from entering from the top of the LM rail. Contact THK for further details regarding mounting.

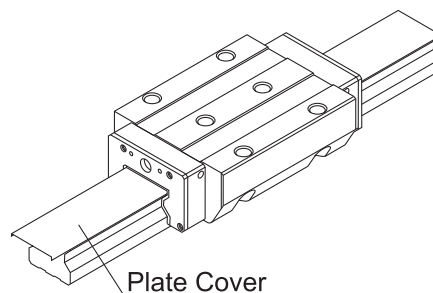

Note 1) The Model SRG with plate cover is not a standard specification. (Please note it is not possible to add just the plate cover afterwards.)

Note 2) The LM block must be removed from the LM rail when mounting. When doing this, a removing/mounting jig (see **A1-549**) is required. Please contact THK for details.

Note 3) Plate covers are available for models SRG 25X to 65.

Greasing Hole

[Greasing Hole for Model SRG]

Model SRG allows lubrication from both the side and top faces of the LM block. The greasing hole of standard types is not drilled through in order to prevent foreign material from entering the LM block. When using the greasing hole, contact THK.

When using the greasing hole on the top face of models SRG-R, SRG-LR and SRG-SLR, a greasing adapter is separately required. Contact THK for details.

If the mounting orientation of the LM Guide is other than horizontal use, the lubricant may not reach the raceway completely.

Be sure to let THK know the mounting orientation and the exact position in each LM block where the grease nipple or the piping joint should be attached.

For the mounting orientation and the lubrication, see **A1-12** and **A24-2**, respectively.

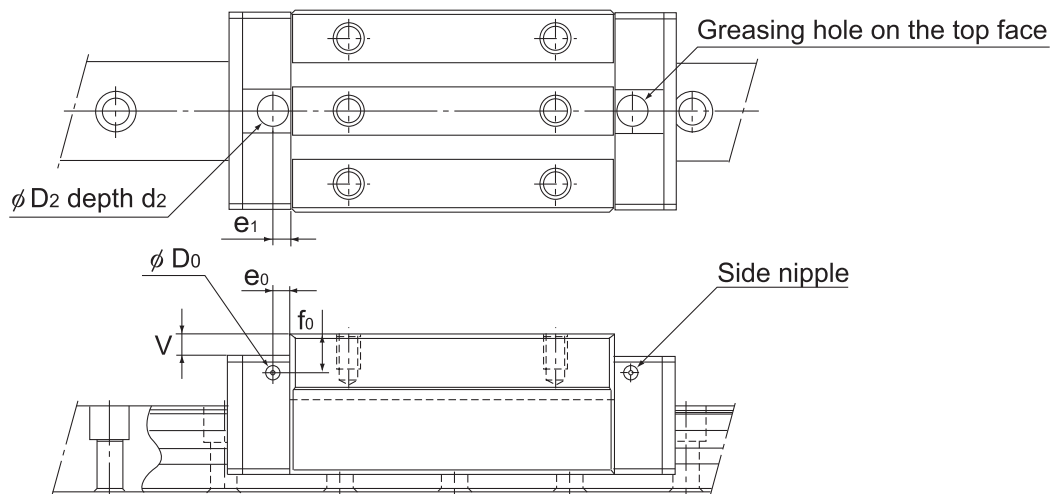

Unit: mm

Model No.	Pilot hole for side nipple			Applicable nipple	Greasing hole on the top face					
	e ₀	f ₀	D ₀		D ₂	(O-ring)	V	e ₁	d ₂	
SRG	15XA 15XV	4	6	2.9	PB107	9.2	(P6)	0.4	5.5	1.4
	20XA 20XLA	4	6	2.9	PB107	9.2	(P6)	0.4	6.5	1.4
	20XV 20XLV	4	6	2.9	PB107	9.2	(P6)	0.4	6.5	1.4
	25XC 25XLC	6	7.3	5.2	M6F	10.2	(P7)	0.4	6	1.4
	25XR 25XLR	6	11.3	5.2	M6F	10.2	(P7)	4.5	6	1.4
	30XC 30XLC	6	7.5	5.2	M6F	10.2	(P7)	0.4	6	1.4
	30XR 30XLR	6	10.5	5.2	M6F	10.2	(P7)	3.4	6	1.4
	35C 35LC 35SLC	6	6	5.2	M6F	10.2	(P7)	0.4	6	1.4
	35R 35LR 35SLR	6	13	5.2	M6F	10.2	(P7)	7.4	6	1.4
	45C 45LC 45SLC	7	7	5.2	M6F	10.2	(P7)	0.4	7	1.4
	45R 45LR 45SLR	7	17	5.2	M6F	10.2	(P7)	10.4	7	1.4
	55C 55LC 55SLC	9	8.5	5.2	M6F	10.2	(P7)	0.4	11	1.4
	55R 55LR 55SLR	9	18.5	5.2	M6F	10.2	(P7)	10.4	11	1.4
	65C 65LC 65SLC	9	13.5	5.2	M6F	10.2	(P7)	0.4	10	1.4
	65V 65LV 65SLV	9	13.5	5.2	M6F	10.2	(P7)	0.4	10	1.4
	85LC	15	22	8.2	PT1/8	13	(P10)	0.4	10	1.4
100LC	15	23	8.2	PT1/8	13	(P10)	0.4	10	1.4	

Note1) The greasing interval is longer than that of full-roller types because of the roller cage effect. However, the actual greasing interval may vary depending on the service environment, such as a high load and high speed. Contact THK for details.

Note2) Upper surface lubrication is for oil lubrication only. Contact THK if you are considering using the greasing hole on the top face for grease lubrication.